

## ◎ POWER RATING

Engine Speed rev/min	Type of Operation	Engine Power	
		kWm	Ps
1800	Continuous Power	332	452
	Prime Power	366	498
	Standby Power	402	546
1500	Continuous Power	297	403
	Prime Power	327	444
	Standby Power	362	492



Note : -. The engine performance corresponds to ISO 3046, BS 5514 and DIN 6271.

-. Ratings are based on ISO 8528.

→ **Prime power** available at variable load. The permissible average power out put (during 24h period) shall not exceed 70% of the prime power rating.

→ **Standby power** available in the event of a main power network failure. No overload is permitted.

## ◎ MECHANICAL SYSTEM

○ Engine Model	P158LE-1
○ Engine Type	V-type 4 cycle, water cooled Turbo charged & intercooled (air to air)
○ Combustion type	Direct injection
○ Cylinder Type	Replaceable wet liner
○ Number of cylinders	8
○ Bore x stroke	128(5.04) x 142(5.59) mm(in.)
○ Displacement	14.618(892.0) lit.(in <sup>3</sup> )
○ Compression ratio	15 : 1
○ Firing order	1-5-7-2-6-3-4-8
○ Injection timing	16° BTDC
○ Compression pressure	Above 28 kg/cm <sup>2</sup> (398 psi) at 200rpm
○ Dry weight	Approx. 950 kg (2,094 lb)
○ Dimension (LxWxH)	1,484 x 1,389 x 1,161.5 mm (58.4 x 54.7 x 45.7 in.)
○ Rotation	Counter clockwise viewed from Flywheel
○ Fly wheel housing	SAE NO.1
○ Fly wheel	Clutch NO.14

## ◎ MECHANISM

○ Type	Over head valve
○ Number of valve	Intake 1, exhaust 1 per cylinder
○ Valve lashes at cold	Intake 0.25mm (0.0098 in.) Exhaust 0.35mm (0.0138 in.)

## ◎ VALVE TIMING

	Opening	Close
○ Intake valve	24 deg. BTDC	36 deg. ABDC
○ Exhaust valve	63 deg. BBDC	27 deg. ATDC

## ◎ FUEL CONSUMPTION

○ Prime Power (lit/hr)	<b>1,500 rpm</b>	<b>1,800 rpm</b>
	25%	28.0
	50%	50.6
	75%	74.7
	100%	102.5
○ Standby Power (lit/h)	<b>1,500 rpm</b>	<b>1,800 rpm</b>
	25%	30.4
	50%	55.8
	75%	83.9
	100%	115.7

## ◎ FUEL SYSTEM

○ Injection pump	Bosch in-line "P" type
○ Governor	Electric type
○ Feed pump	Mechanical type
○ Injection nozzle	Multi hole type
○ Opening pressure	285 kg/cm <sup>2</sup> (4,054 psi)
○ Fuel filter	Full flow, cartridge type
○ Used fuel	Diesel fuel oil

## ◎ LUBRICATION SYSTEM

○ Lub. Method	Fully forced pressure feed type
○ Oil pump	Gear type driven by crankshaft
○ Oil filter	Full flow, cartridge type
○ Oil pan capacity	High level 28 liters ( 7.40 gal.) Low level 26 liters ( 6.86 gal.)
○ Angularity limit	Front down 35 deg. Front up 35 deg. Side to side 35 deg.
○ Lub. Oil	Refer to Operation Manual

## ◎ COOLING SYSTEM

- Cooling method Fresh water forced circulation
- Water capacity 20 liters ( 5.28 gal.)  
(engine only)
- Pressure system Max. 0.9 kg/cm<sup>2</sup> ( 12.8 psi)
- Water pump Centrifugal type driven by belt
- Water pump Capacity 410 liters ( 108.2 gal./min)  
at 1,800 rpm (engine)
- Thermostat Wax – pellet type  
Opening temp. 71°C  
Full open temp. 85°C
- Cooling fan Blower type, plastic  
915 mm diameter, 7 blade

## ◎ ELECTRICAL SYSTEM

- Charging generator 24V x 45A alternator
- Voltage regulator Built-in type IC regulator
- Starting motor 24V x 7.0kW
- Battery Voltage 24V
- Battery Capacity 200 AH (recommended)
- Starting aid (Option) Block heater

## ◎ ENGINEERING DATA

- Water flow 342 liters/min @1,500 rpm  
410 liters/min @1,800 rpm
- Heat rejection to coolant 40.1 kcal/sec @1,800 rpm
- Heat rejection to CAC 18.6 kcal/sec @1,800 rpm
- Air flow 25.3 m<sup>3</sup>/min @1,500 rpm  
31.1 m<sup>3</sup>/min @1,800 rpm
- Exhaust gas flow 78.3 m<sup>3</sup>/min @1,500 rpm  
91.3 m<sup>3</sup>/min @1,800 rpm
- Exhaust gas temp. 606 °C @1,800 rpm
- Max. permissible restrictions
  - Intake system 220 mmH<sub>2</sub>O initial  
635 mmH<sub>2</sub>O final
  - Exhaust system 600 mmH<sub>2</sub>O max.

## ◆ CONVERSION TABLE

in. = mm x 0.0394	lb/ft = N.m x 0.737
PS = kW x 1.3596	U.S. gal = lit. x 0.264
psi = kg/cm <sup>2</sup> x 14.2233	kW = 0.2388 kcal/s
in <sup>3</sup> = lit. x 61.02	lb/PS.h = g/kW.h x 0.00162
hp = PS x 0.98635	cfm = m <sup>3</sup> /min x 35.336
lb = kg x 2.20462	

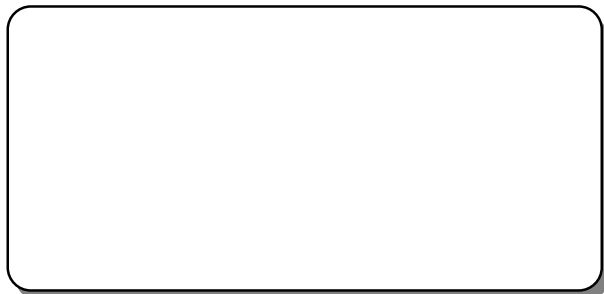
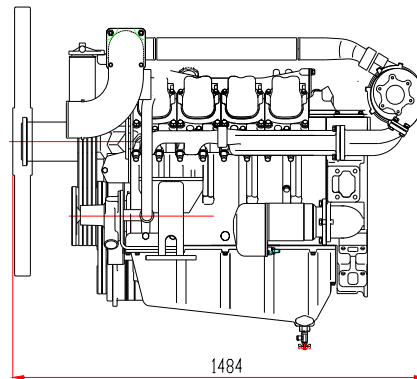
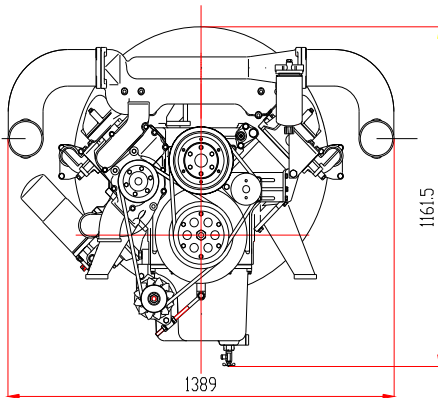

**Head office**  
7-11, Hwasu-Dong, Dong-Gu, Incheon, Korea  
TEL : 82-32-760-1437, 1964 FAX : 82-32-760-1964

**Seoul Office**  
Doosan Infracore Co. Ltd.,  
22nd Floor, Doosan Tower, 18-12, Euljiro 6-ga, Jung-gu,  
Seoul, Korea.  
TEL : 82-2-3398-8521~8535 FAX : 82-2-3398-8509  
Web site : www.doosaninfracore.com

\* Specifications are subject to change without prior notice